

JBL Professional Series

Model 4301 Broadcast Monitor

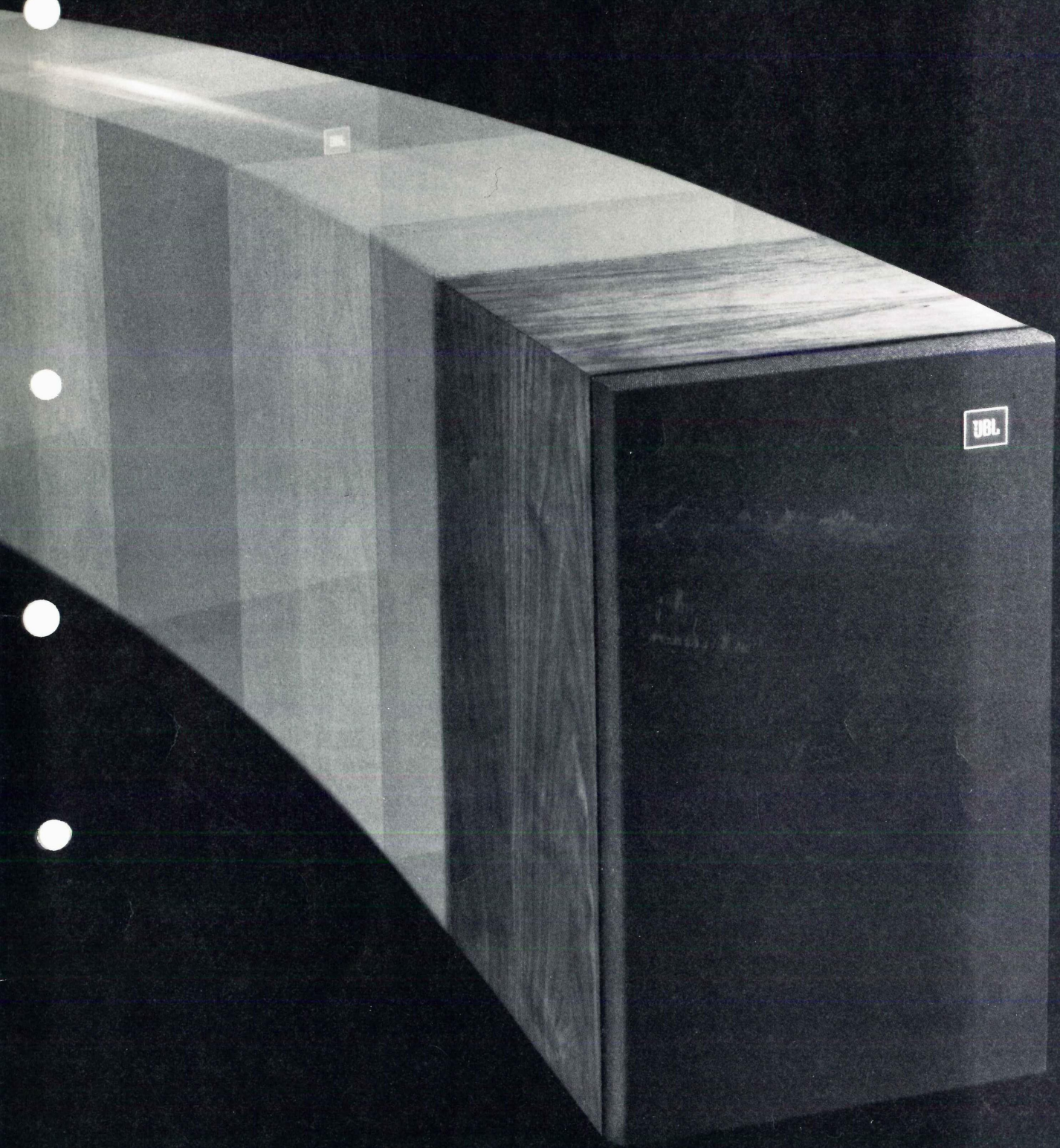

Model 4301 Broadcast Monitor

Accurate, smooth reproduction 45 to 15,000 Hz, ± 3 dB

39 dB SPL at 30 feet with a 1-milliwatt input

88 dB SPL at 1 meter with a 1-watt input

Components: 8-inch low frequency loudspeaker, 1.4-inch high frequency direct radiator

Balance control located behind the removable grille

Oiled walnut enclosure

A compact monitor loudspeaker system designed specifically for broadcast applications, the 4301 delivers the wide band sound reproduction, accuracy and efficiency required by improved broadcast technology. Use of the 4301 is particularly relevant in light of the most recent broadcast developments, including TV/FM stereo simulcasting, AM stereo and multiplex television audio. Just as a video engineer wouldn't think of judging image quality on a household television receiver, an audio engineer shouldn't consider monitoring AM, FM, TV or film sound on anything less than a studio-quality loudspeaker system.

A professional monitor, such as the 4301, is of particular importance for monitoring the quality of the transmitted signal in order to detect and control spurious noise, i.e., turntable rumble, air conditioning and other acoustic interference picked up by open microphones, tape hiss or cue tone leakage. Such noise results in loss of broadcast power as well as signal degradation. Previously, monitoring these sounds would have been inconsequential since they exceeded the bandwidth or definition capabilities typical of audio transmission and reception. However, the competition for quality among broadcasters, enhanced by marked improvements in recorded program material, have resulted in a generation of equipment capable of transmitting high fidelity signals virtually equal to the program material. This, coupled with increased listener awareness of sound quality, has resulted in industry-wide improvement in broadcast technology, making accurate monitoring absolutely essential.

The 4301 shares its basic performance characteristics with all other JBL monitors—exceptional clarity, wide dynamic range, solid bass and open high frequency reproduction. The 4301 is efficient enough to produce a sound pressure level of 98 dB in a typical broadcast booth of 6' x 10' x 8' (1.8 x 3.0 x 2.4 m) with an amplifier delivering only 10 watts rms. The compact enclosure of the 4301 is designed to fit the smaller spaces typical of broadcast control booths, production studios or mobile recording, broadcast and film editing facilities.

Low Frequency Loudspeaker

The 4301 utilizes a low frequency loudspeaker specifically engineered for a compact enclosure without the compromises usually associated with smaller drivers. The 8-inch (20 cm) loudspeaker exhibits unusually smooth frequency response, wide dynamic range, superior transient reproduction and low distortion for a unit of compact size. It features a precision die-cast aluminum frame for structural integrity under the most severe operating conditions. The 2-inch (5 cm) diameter copper voice coil is suspended in a magnetic field having a flux density of 8500 gauss. The magnetic field is generated by a 2½-pound (1.1 kg) low-loss magnetic assembly energized by an Alnico V magnet. Mass and compliance of the integrally stiffened cone have been carefully selected to optimize low frequency bandwidth and definition while reducing distortion. As with all JBL loudspeakers, this unit provides maximum power handling capacity and efficiency consistent with the bandwidth expected of the device.

High Frequency Direct Radiator

The open, crisp treble performance of the 4301 is the product of a 1.4-inch (3.6 cm) direct radiator designed for clarity, smoothness of response and power handling capacity. The ¾-inch (1.6 cm) copper voice coil is large in relation to cone size for efficiency and transient reproduction with definition and accuracy, yet the diameter of the cone and center dome has been kept small to obtain wide dispersion. The magnetic assembly weighs 1½ pounds (0.7 kg) and generates a flux density of 15,000 gauss. The entire direct radiator is surrounded by a ring of dense foam damping material to absorb spurious radiation and reflections.

Frequency Dividing Network

Smooth control of the component loudspeakers is achieved by a frequency dividing network engineered and tested to complement the electrical and acoustical characteristics of the system. The dividing network is fitted with a continuously variable control that permits adjusting the relative level of the high frequency direct radiator to suit listening preferences and room conditions. The control does not affect the crossover frequency, nor does it limit the upper frequency response of the loudspeaker system.

Enclosure

Size and configuration of the 4301 enclosure have been carefully matched to the acoustic characteristics of the component loudspeakers as well as the intended use of the complete system. To achieve maximum strength and resistance to vibration, all enclosure joints interlock, are hand fitted and wood welded; all panels are constructed of ¾-inch (19 mm) dense compressed stock. This material, also known as particle board, is preferred to solid wood for its superior acoustical properties. Acoustic damping material is applied to the interior surfaces of the side and back panels to attenuate standing waves within the enclosure. A ducted port extending through the baffle panel provides proper acoustical loading of the low frequency loudspeaker. All components mount directly to the baffle panel and are removable from the front of the enclosure. The four side panels are veneered with solid American Black Walnut, hand rubbed to a rich, lustrous finish enhancing the natural beauty of individual grain structure and color.

Test Conditions

The accompanying graph and specifications were compiled from measurements made under carefully controlled conditions. The loudspeaker system was mounted flush in the center of a large, flat baffle in a non-reverberant environment. Laboratory-standard condenser microphones were suspended in a spherical pattern around the acoustic center of the system, sufficiently distant to be out of the near field, so that data taken would reflect the total output of the combined transducers. In keeping with accepted laboratory practice, all equipment was checked and calibrated before tests were conducted.

Bandwidth On-Axis

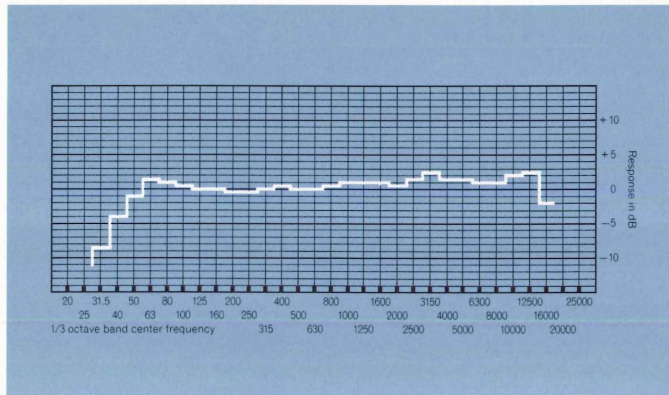

Frequency response of the 4301 taken with 1/3-octave band pink noise. Measured response contour of a typical system averaged through an inclusive arc of 30° in the vertical and horizontal planes does not deviate more than 3 dB from the above curve.



Loudspeaker system components of the 4301 Broadcast Monitor

JBL continually engages in research related to product improvement. New materials, production methods and design refinements are introduced into existing products without notice as a routine expression of that philosophy. For this reason, any current JBL product may differ in some respect from its published description but is always warranted to equal or exceed the original design specifications unless otherwise stated.

Specifications

Maximum Power Input ¹	15 watts rms at 8 ohms
Nominal Impedance	8 ohms
Power Output ²	88 dB SPL measured at 10 ft. (3.0 m) in a room volume of 2000 cu. ft. (56.6 m ³) with ½ rated power input (-3 dB)
Frequency Response	
Sine Wave, On-Axis	45 to 15,000 Hz, ± 3 dB
½-Octave Band (400 Hz Reference)	- 3 dB at 50 Hz 0 dB at 1200 Hz + 2 dB at 12 kHz
Polar Response	No less than - 6 dB at 90° horizontal and vertical to 10 kHz
Sensitivity	39 dB SPL measured at 30 feet (9.1 m) with a 1-milliwatt input averaged from 500 to 2500 Hz 88 dB SPL measured at 1 meter (3.3 ft.) with a 1-watt input averaged from 500 to 2500 Hz
Distortion	
½ Power, 87 dB SPL/10 ft. (3.0 m), Single Frequency	0.5% or less third harmonic generation from 100 to 15,000 Hz
Crossover Frequency	2500 Hz
Finish	Oiled Walnut
Grille	Dark Blue fabric
Enclosure Volume	1 cu. ft. 28 liters
Enclosure Dimensions	19" x 12 1/8" x 11 1/4" deep 48.3 x 30.6 x 29.1 cm deep
Net Weight	26 lbs 12 kg
Shipping Weight	29 lbs 13 kg

1. The 4301 may be driven by amplifiers rated up to 60 watts rms (per channel) if normal precautions against input device distortion or amplifier clipping are followed.
2. Power output measured with a B&K Impulse Precision Sound Level Meter.

JBL Professional Products are not intended for household use.

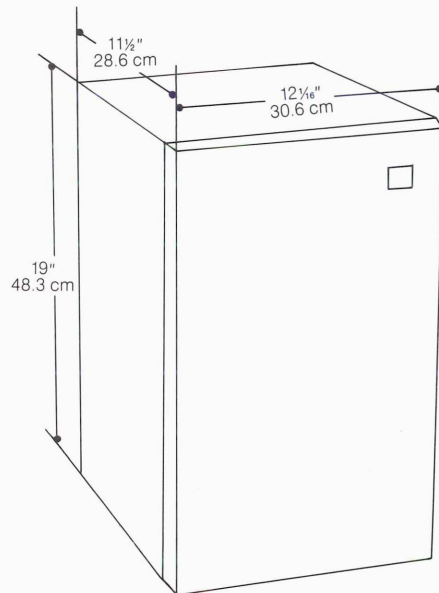



Professional Division

James B. Lansing Sound, Inc.,
8500 Balboa Boulevard, Northridge, California 91329

BETTER YOU THAN THEM.

Today's broadcasting equipment and standards let you to transmit things you never could before.

Like tape hiss, cue tone leakage and turntable rumble, just to name a few.

And that's precisely why you need the JBL 4301 Broadcast Monitor.

It lets you hear everything you're transmitting. All the good stuff. And, all the bad. So you can detect the flaws before your listeners do.

The 4301 is super-compact, 19" h x 11½" d x 12¼" w. So it fits all EIA Standard rack shelves. It costs \$168. And it's made by JBL. The recognized leader in professional sound equipment.

Just give us your name and address and we'll send you all the 4301's very impressive specs.

Along with the name of your nearest JBL Professional Products Dealer.

He'll tell you everything you need to hear.



GET IT ALL.

